

BDH

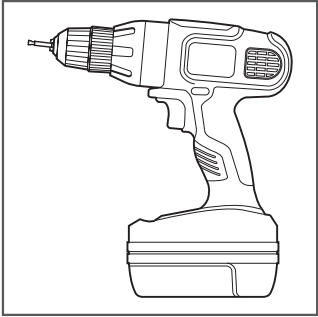

Classic Z Barn Door

ASSEMBLY INSTRUCTIONS

CLASSIC Z BARN DOOR Recommended Tools



Drill with Phillips Bit

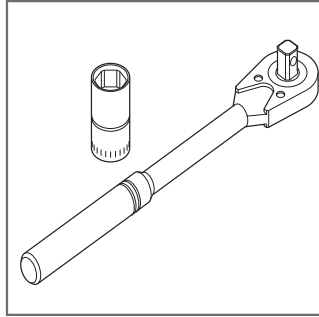

Socket Wrench with
7/16" Socket

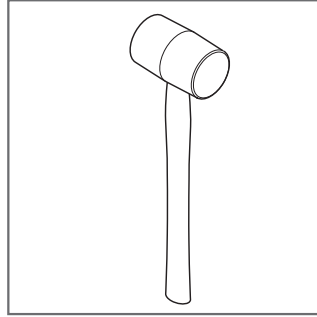

Rubber Mallet

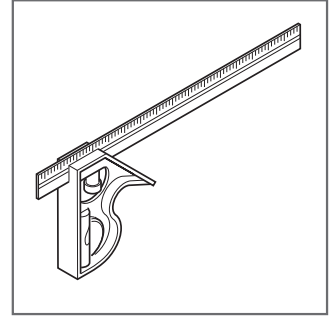

Adjustable Square

CLASSIC Z BARN DOOR Specifications

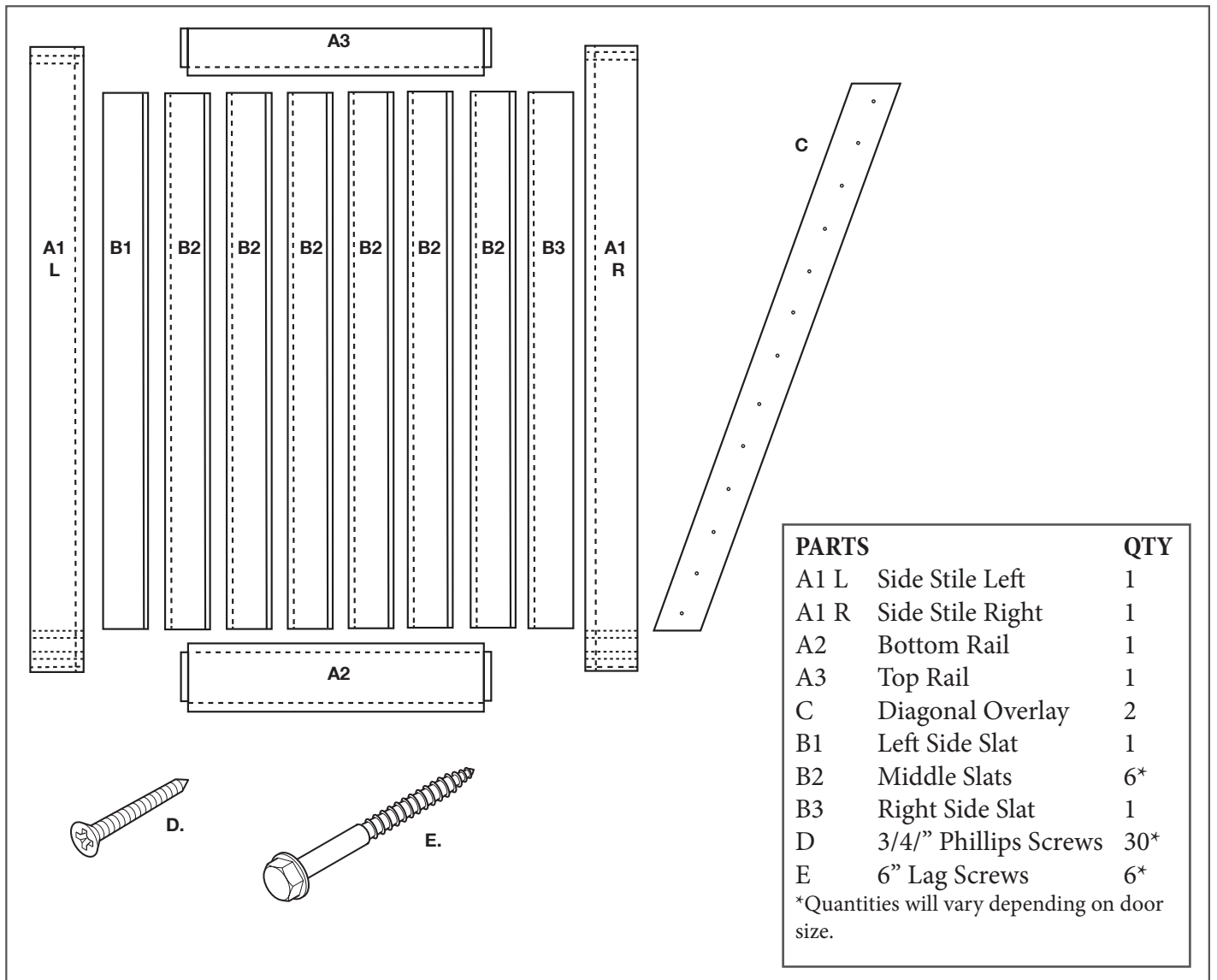

CLASSIC Z BARN DOOR Parts

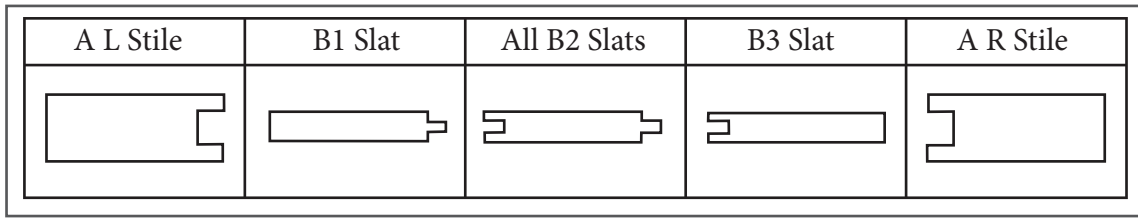

Slat and Stile End Views

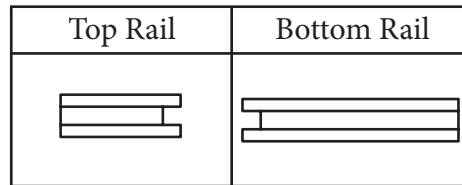

Rail End Views

FIRST THINGS FIRST

Lay out all wood parts before beginning assembly to ensure parts have not been damaged in shipping. If damage has occurred, call 1(888) 909-6546 and BarnDoors & Hardware will expedite a replacement.

NOTE:

This door model comes in various sizes. The instructions have been written for the average single door size; but larger doors may have more wood and fastener parts.

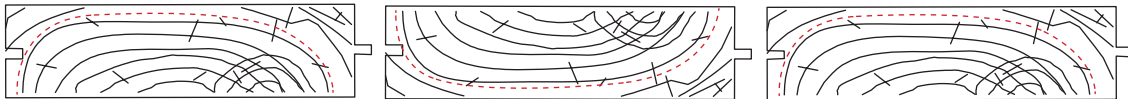

NOTE:

Always alternate the direction of the wood grain when assembling slats. This will add strength to the assembly and help prevent warpage.

NOTE:

Doors using Floor Mount Door Guides will have a groove on the bottom edge. Ensure this groove is on the bottom when hanging the door.

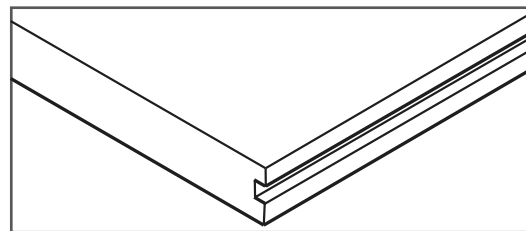

USE TEAMWORK - WE RECOMMEND TWO PEOPLE FOR THIS BUILD.

CLASSIC Z BARN DOOR Assembly Instructions

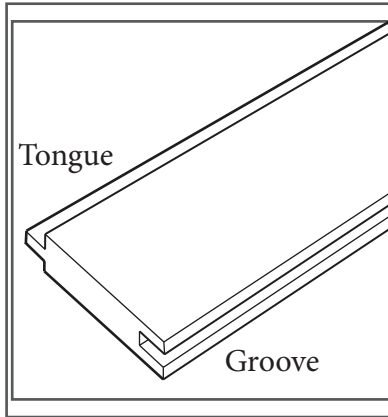

By Definition:

Tongue and Groove

Tongue refers to the ridge extending beyond the main portion of the slat or stile. Groove refers to the slot cut into the other side of the slat or stile.

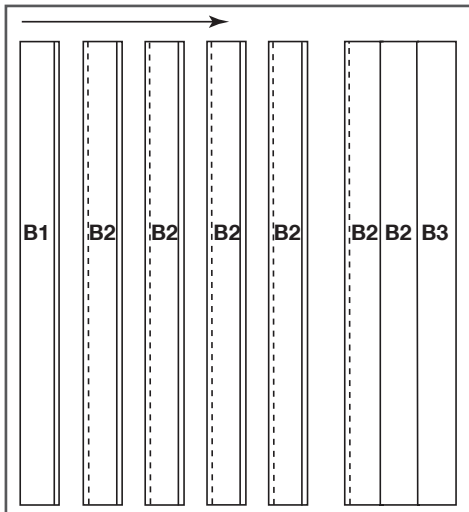

Figure 1

NOTE:

The following should be a 'dry' assembly. Do not use adhesives in when putting this door together.

1. On a flat, clean surface, lay out the right slat (B3) with the groove facing to the left. Lay all B2 slats next to B1 with the tongue facing to the left. Lay the left slat (B3) to the left of the last B2 Slat with the groove facing right. Assemble by fitting the tongue into the groove of each piece. Gently tap into place with a rubber mallet to seat the slats together (Figure 1).

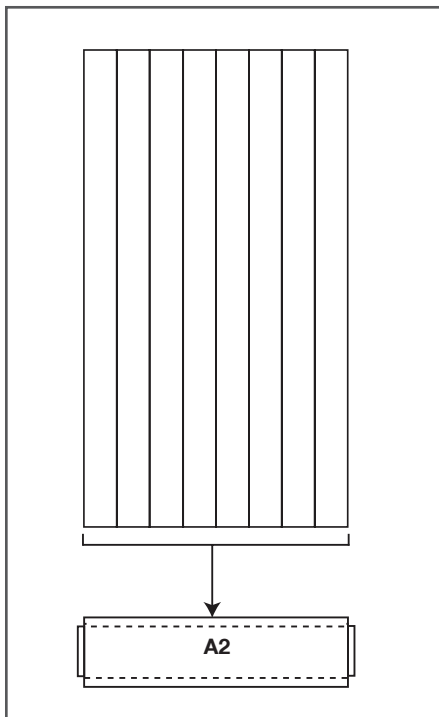

Figure 2

SUGGESTION

Use an adjustable or fixed carpenter's square to ensure all sides of the door are square to each other.

2. Place the bottom rail (A2) below the assembled slats. Slide upward to cover the lower edge of the slat assembly. Tap the bottom rail into place with a rubber mallet (Figure 2).

CLASSIC Z BARN DOOR Assembly Instructions

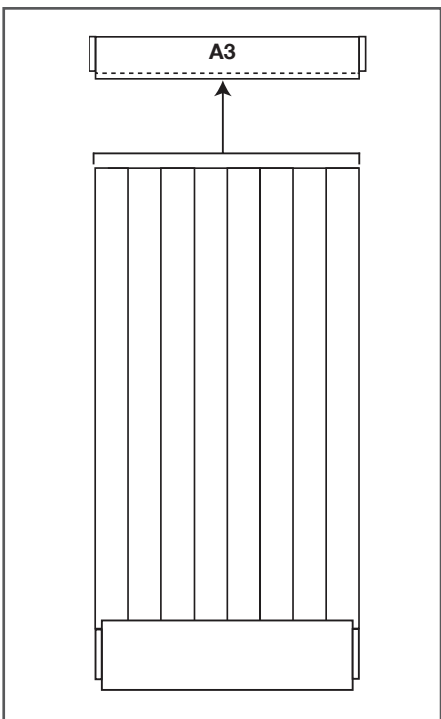

Figure 3

3. Place the Top Rail (A3) above the assembled slats. Slide downward to cover the upper edge of the slat assembly. Tap the Top Rail into place with a rubber mallet (Figure 3).

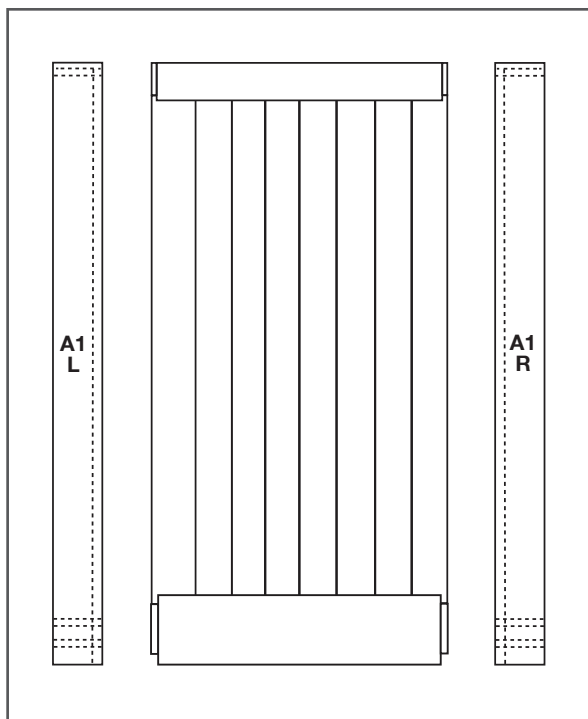

Figure 4

4. Place the left side style (A1 L) beside the assembled slats and rails. Slide to the right to cover the top and bottom rail tongues and the edge of the slat assembly. Tap the rails into place with a rubber mallet. Repeat with the right stile (A1 R) (Figure 4).

CLASSIC Z BARN DOOR Assembly Instructions

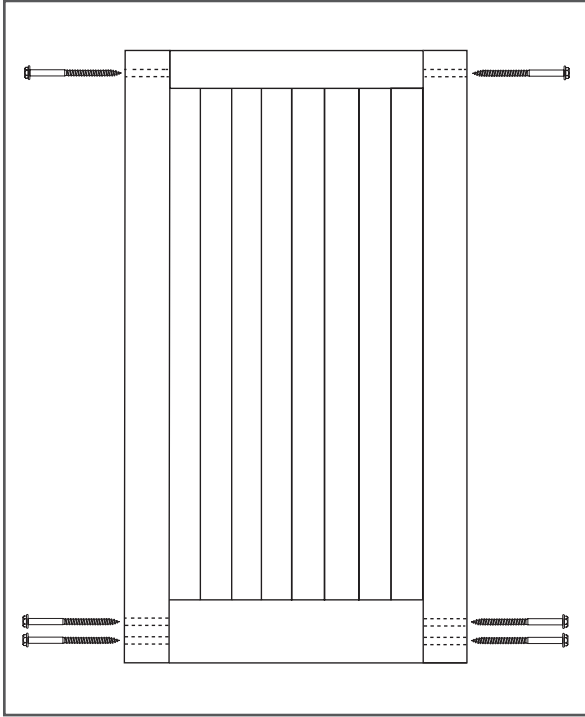

Figure 5

5. Fix the door assembly with six 6" lag screws (E), using a socket wrench with a 7/16" socket (Figure 5).

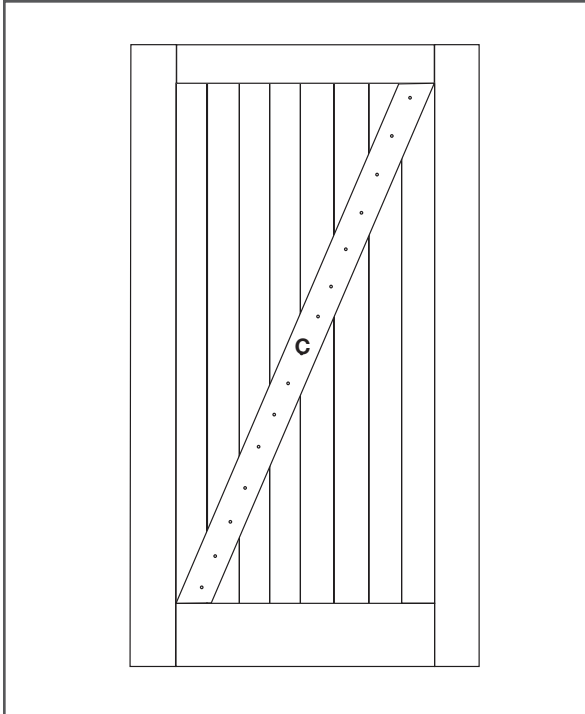

Figure 6

6. Lay the Diagonal Overlay (C) across the slats. Attach to slats and with 15 phillips screws (D) using a drill with a phillips bit (Figure 6).

7. Turn the door over. Repeat step six for the other side.

We Love What You Are Doing With The Place

**Congratulations on your decision to bring home
An American made product of the highest quality.
We hope your Classic Z Barn Door brings art and function
into your life.**

**Designed and crafted
entirely in the
U.S.A.**

